

C. Hopkins.
Re-jewelling Watches.
N^o 94,208. Patented Aug. 31, 1869.

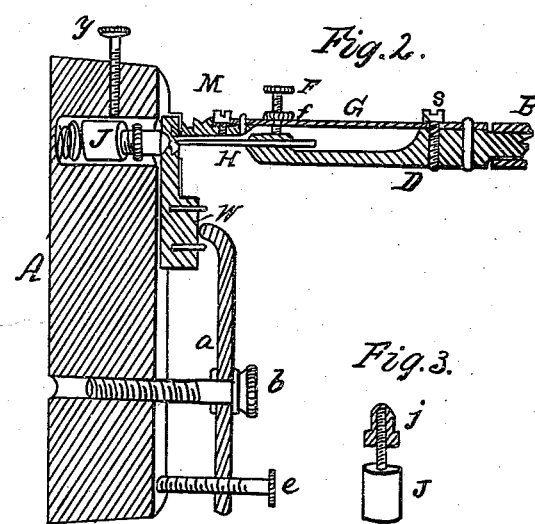
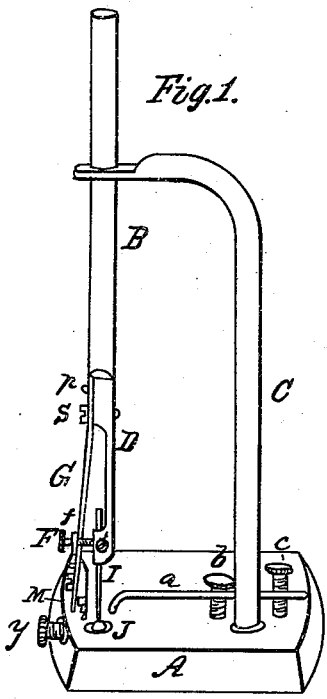

Fig. 4 & 5. Fig. 7 & 8. Fig. 10 & 11. Fig. 13 & 14.

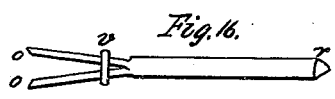
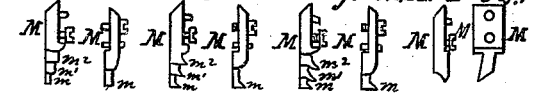

Fig. 17.

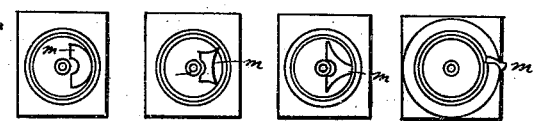

Fig. 6. Fig. 9. Fig. 12. Fig. 15.

Witnesses.
H. Mulligan
John Pratt

Inventor
C. Hopkins

United States Patent Office.

C. HOPKINS, OF PHILADELPHIA, PENNSYLVANIA.

Letters Patent No. 94,208, dated August 31, 1869; antedated August 19, 1869.

IMPROVEMENT IN APPARATUS FOR REJEWELLING WATCHES.

The Schedule referred to in these Letters Patent and making part of the same.

To all whom it may concern:

Be it known that I, C. HOPKINS, of the city of Philadelphia, in the county of Philadelphia, in the State of Pennsylvania, have invented a new and useful Improvement on the Improved Tool for Rejewelling Watches, invented by me, and for which Letters Patent were granted on the 9th day of June, 1868; and I do hereby declare that the following is a full, clear, and exact description of the construction and operation of the same, reference being had to the annexed drawings, making a part of this specification, in which—

Figure 1 is a perspective view of the tool, complete in all its parts, and in the position in which it stands when in use.

Figure 2 is an enlarged section of the same, together with a section of a watch-bridge in the position of being operated upon.

Figure 3 is a hollow cone placed over an indented centring-piece, and is attached thereto by means of screw-threads, cut on the exterior of the one, and interior of the other piece.

Figures 4 to 15 are side and end views of several forms of reaming and cutting-parts for the reaming-instrument.

Figure 16 is a spring-fork burnisher.

Figure 17 is a bent form of needle for the reaming-instrument.

In order to a satisfactory performance of the watch, it is highly important in all cases of setting pivot-hole jewels in it, that the following particulars should be strictly attended to, namely:

First, the opening, or bezel, should be circular in form, and accurately centred.

Second, the bed, or seat on which the jewel is to rest, should be at the proper depth from the surface of the plate, level, and perfectly upright, so that when fastened down in its place, the pivot-hole in the jewel will stand at exact right angles with the surface of the plate.

The only tool heretofore used by watch-repairers, with which these several points could be secured with any degree of accuracy, under all circumstances, has been what is known as the universal lathe, in some one or other of its modifications; a tool which, from its expense, is possessed by only a few, while to all others in the watch-repairing business, jewel-setting, particularly that part of it relating to the forming of new settings, and repairing badly-damaged old settings, has been quite beyond their ability to perform. To obviate these difficulties, however, and to place within the reach of all, a simple apparatus, by use of which, even the least experienced watch-repairer may readily perform the work of jewel-setting in all its parts, neatly and accurately, I have invented the im-

provement on tools for this purpose, hereinafter described.

In the drawings—

A represents a metallic bed, of any appropriate form, on which the piece of watch to be jewelled is laid, and to which it is fastened by means of the lever-clamp *a*, which I make somewhat of the form and operate in the manner shown in fig. 3, where the bent end of the clamp is represented as pressing downward on the watch-bridge *P*, in proportion as the other end is lifted, by means of the thumb-screw *c*, which, as shown, passes through the end of the clamp, with its end resting on the top of the bed *A*.

J is a combination adjustable centring-piece, which I make and use in the following manner:

The piece *J*, I make of a piece of round steel, of suitable size and length, about one-third or one-half the length of which I reduce in size, and cut a screw-thread around its periphery, as shown in the drawing, fig. 3.

I then cut away the screw-thread from the end of the piece *J* to the distance of about one-eighth or one-sixteenth of an inch, and reduce this part to a size sufficiently small to enter from the back, or from below the smallest-sized hole that ever requires to be jewelled; after which I drill a small hole in the extreme end, of sufficient size and depth to form a female centre, or receptacle, for the point of the centring-needle *I*.

This done, I form a kind of semi-cone, *j*, of the form designated, with a female screw cut in its interior about two-thirds or more of the length of the piece from the bottom upward, of suitable size to fit on the male screw of the piece *J*, and then, from the upper end of the screw, through the point of the cone, I make a smooth, round opening, that will pass snugly over the small cylindrical end of the piece *J*.

This completed, I place the united pieces on a spiral spring within a bore of suitable size and depth, formed in the body and near one end of the bed *A*, and then, by means of the thumb-screw *y*, which passes from the side or end of the bed-piece into the bore referred to, I fasten the combination spring-centre, just described, at any depth or height required.

By this contrivance I provide a means by which, through a simple adjustment of the cone *j* on the piece *J*, the operator is enabled to get instantly, the centre, and to preserve with accuracy, the appropriate depth of the socket or bezel on which he is operating.

C is a crane-shaped uprighting-piece attached to the bed *A*, through the bent upper end of which a circular opening is formed, and so placed as to stand exactly perpendicular above the centring-piece *J*.

And through this opening in the uprighting-piece C, the handle B, of the reaming-instrument is passed while in use, the point of the centring-needle I, the meanwhile, resting in the female centre in the piece J.

The reaming and cutting-instrument is composed substantially of the following parts, namely:

The handle B, the elongated shank, D, the centring-needle I, the spring-arm G, the thumb-screw and set-nut F *f*, and the reaming and cutting-points M, the last named being made of several different forms, to adapt them to the different parts of the work required to be performed with them, and the centring-needle I being made either straight, as represented in figs. 1 and 2, or bent in form, as shown in fig. 17; the bent form of needle being specially adapted for use where the reaming-instrument is required to be operated in small settings, the bend in the needle allowing, as it does, the reaming or cutting-part M, to fall in much closer or nearer the centre than it can possibly do when a straight needle is used; also, by making the point blunt, and bending the extreme end back or outward somewhat more than is represented in fig. 17, this form of needle may be so adjusted, in connection with the smooth reaming-piece M, that the bent end of the needle will pass in under the flange of the setting, and its point rest down on the jewel-seat, while the reaming-piece presses against the opposite side of the setting, and the instrument be thus made to operate from opposite sides of the setting, instead of from the centre outward.

The other parts of the reaming-instrument, I make as follows:

The handle B, I make of any suitable material, cylindrical in form, and with a hollow cavity in its lower end to receive and hold the upper end of the shank D, or the handle and shank may be made all in one piece.

The shank D, I make of square or octagonal-shaped steel or iron, which I hollow out or cut away on one side, as shown in the drawings; after which I drill a hole or bore longitudinally through its lower end, to form the receptacle for the centring-needle I, which I fasten in position by means of the set-screw *z*.

The spring-arm G, I make of flat steel, of appropriate width and thickness, which, when finished, I attach to the side of the shank D by means of the screw S and the steady-pin *p*, just back of it, the spring, as thus placed, being so set that it will draw in close against the shank at its lower end, when at rest, but by means of the thumb-screw F, which is passed through the arm in such position that when turned inward, its point will press against the shank near its lower end, the arm may be forced outward, as occasion requires, while the set-nut *f* serves to fix a distance beyond which the screw cannot force the arm when in use.

The reaming and cutting-pieces M, I make of best cutting-steel, in separate or detached pieces from the arm G, and when finished, I attach them to the end of the arm, as required, by means of two small screws, or a single screw and a steady-pin, the pieces being made so as to be attachable to either the upper or the under side of the arm, as preferred.

Or, when so desired, the reaming-parts M may be formed on the ends of the spring-arms, instead of in detached pieces, as was the case in my original invention.

For lifting up the flange, or merely opening the mouth of the setting, I use a smooth, half-round piece, M, of one or other of the forms indicated by figs. 4 and 5, fig. 6 being an enlarged end view alike of both the other figures; and for cutting the inner groove to form the jewel-seat, I use one or other of the form of cutters represented by figs. 7, 8, 9, 10, 11, 12, and for forming the ring or bevelled sink around the mouth of

the setting in the face of the plate, I use the form of cutter represented by figs. 13, 14, and 15.

Or, by slight modifications in these forms, especially in the angles of most of the reaming and cutting-pieces M represented, they may, in some cases, be rendered more effective or prompt in their action than when the forms in the drawings are closely adhered to.

The spring-fork burnisher, I make of a piece of steel, split into the form of a fork with two prongs, the ends of which prongs I bend inward at equal angles of about thirty degrees to forty-five degrees, as represented at *o o*, fig. 16, and then round off the edges and carefully polish the acting parts.

Before tempering the prongs, however, I set them so they will stand apart considerably at their ends when left free, and I then pass a hollow slide over and around them, with which to force them together, or to set them at the required distance from each other.

Or the prongs may be set so they will stand close together when left free, and then be forced apart and set at the required distance from each other, by means of a thumb-screw working in the same way as the screw F of the reaming-instrument.

The burnisher, as thus described, I use in burnishing down the lips of the setting over the edges of the jewel after it has been dropped into its place, the prongs of the burnisher, in this operation, being first set at the proper distance from each other, and then placed astride of the jewel, with one of the bevelled ends pressing down on one side and the other on the opposite side of the setting. Then by rotating the burnisher with the fingers while held in this position, the work of fastening the jewel in its place is quickly and neatly accomplished.

The parts of my invention herein referred to or described, that are substantially the same as in the specification of my original invention, for which Letters Patent were granted on the 9th of June, 1868, are, the bed A, the centring-needle I, the three steps or ledges *m m' m''* on the pieces M of the reaming-instrument, and the handle B, all the other parts and their combinations being embraced within my present improvement.

The mode of using this, my improved invention, is as follows:

I first loosen the set-screw *y*, so as to allow the centring-pieces J *j* to be lifted by the spiral spring under them, above the top of the bed A.

I then adjust the two pieces so that the cone *j*, when set snugly into the countersink in the back of the plate, will bring the small indented end of the piece J within the hole to be jewelled, to such depth that its extreme end will stand level with the seat on which the jewel is to rest.

Having thus adjusted these pieces, I place the back of the hole to be operated upon, over the end of the cone, and with the thumb or finger press it downward until the plate or bridge, as the case may be, rests on the top of the bed A, at which point I fasten the back centre by tightening the set-screw *y*, and in which position I also firmly clamp the piece to be jewelled, as shown at P, fig. 2.

I then adjust the centring-needle I, so that when its end or point rests on the bottom of the indentation or bore in the end of the piece J, the reaming or cutting-piece M will stand at the exact depth required within the hole to be operated upon.

This done, I pass the handle B through the opening for it in the top of the uprighting-piece C, and step the point of the needle I into the indentation in the end of the centring-piece J, and then, taking hold of the handle B with one hand, and keeping the point of the needle I pressed down snugly into the back centre with the other hand, I turn the screw F until the piece M is forced outward sufficiently to come into

contact with the walls or edges of the bezel, and I then rotate the instrument with the fingers until the setting is fully opened out, or the channel required in forming the jewel-seat is cut out to the desired extent.

The mode of using the cutter for forming the bevelled sink around the mouth of the setting, and also for using the blunt form of bent needle hereinbefore referred to, is so nearly similar to that just described, any one having occasion to use them will readily understand the proper way of doing so, always bearing in mind, however, that in forcing the cutting and reaming-pieces outward, it should be done gradually, and with some degree of care, as the work progresses, otherwise breakage of the reaming-point or damage to the setting may result.

Having thus prepared the setting to receive the jewel, I drop it into its place and fasten it there by means of the spring-fork burnisher, as previously described.

Having thus fully described the construction and operation of my improved invention, so that any one skilled in the work can successfully use the same,

What I claim as new, and desire to secure by Letters Patent is—

1. The combination of the adjustable spring-centre and the centring-needle I, with the reaming and cutting-pieces M, all constructed, arranged, and operated together, substantially in the manner described.

2. The burnisher herein described, constructed with two prongs bevelled inward at their ends, substantially as specified.

3. The improved rejewelling-apparatus herein described, its constituent parts operating together as set forth.

C. HOPKINS.

Witnesses:

G. W. WOOLLEY,
CHARLES KLOMANN.